

Research Article

The Role of Intrinsic Motivation on Altruism, Civic Virtue, Affective Commitment and Work Engagement

Muchtadin^{1*}, Zelvy Emmelya Sundry²

¹ Management Study Program, Faculty of Economic and Business, YPPI Rembang University

² Nursing Science Program, STIKES Citra Delima Pangkalpinang

Received: 28-07-2023; Accepted: 29-09-2023

Abstract

Intrinsic motivation plays a pivotal role in shaping various dimensions of nursing practice. This study investigates how intrinsic motivation influences altruism, civic virtue, affective commitment, and work engagement among Bakti Timah Medika nurses. A sample of 134 nurses was selected through accidental sampling. This research uses a quantitative approach to analyze Partial Least Squares Structural Equation Modeling (PLS-SEM). The findings reveal a significant positive correlation between intrinsic motivation and altruism, civic virtue, affective commitment, and work engagement. Notably, work engagement demonstrates the most substantial impact of intrinsic motivation. Furthermore, this study suggests a potential mediator role of work engagement between inherent motivation and altruism, civic virtue, and affective commitment. By shedding light on the influence of intrinsic motivation on essential work outcomes (altruism, civic virtue, affective commitment, and work engagement) within the health sector, this research contributes to enhancing nursing practices.

Keywords: affective commitment, altruism, civic virtue, intrinsic motivation, work engagement

JEL Classification: M12, M54, D23

How to cite: Muchtadin, Sundry, Z. E., (2023). The Role of Intrinsic Motivation on Altruism, Civic Virtue, Affective Commitment and Work Engagement, *Research of Economics and Business (REB)* 1(2), 86-94

Corresponding author: Muchtadin (mmuchtadinmuch12@gmail.com)



This is an open-access article under the [CC-BY-SA](https://creativecommons.org/licenses/by-sa/4.0/) international license

1. Introduction

Health has an important role for the population in a country. Health enables a person to perform various activities such as work, play, and study. Nurses have their role in health in a country. Nurses play an important role for organizations in the health sector. The presence of nurses can support the patient's healing process, which ultimately benefits the organization. Service practices provided by nurses play a positive role in the quality of care, patient satisfaction, and waiting time (Jennings et al., 2015).

The management shift from PT Timah Tbk to PT Pertamina Bina Medika led to a change in policy towards its employees, one of whom was a nurse. Labor efficiency through reducing employees, benefits, and demands for continuing to graduate school can reduce nurses' attachment to their work, reduce nurse commitment, and make employees less voluntary and involved.

One important aspect that nurses need to have is intrinsic motivation. Intrinsic motivation plays a role in improving performance in terms of quality (Cerasoli et al., 2014). Intrinsic motivation was found to be able to reduce turnover intention and burnout in nurses (Wang et al., 2019). The invitation to work together makes workers more intrinsically motivated and turns work into play (Carr & Walton, 2014). Nurses participating in professional training activities for 7 days each year have higher intrinsic motivation (Toode et al., 2015). Intrinsic motivation was found to impact work outcomes such as altruism, civic virtue, affective commitment, and work engagement (Buch, 2015; Güntert, 2015; Putra et al., 2015).

Altruism and Civic Virtue are components of organizational citizenship behavior (H. Kim, 2014). Nurses with high altruism tend to help other nurses who do not come to work and are more willing to work and help other nurses with a high workload (Grego-Planer, 2019). Nurses with high civic virtue will increasingly contribute and be positively responsible for their organizational governance (Khan et al., 2020). Altruism and civic virtue were positively related to organizational effectiveness (Kumari & Thapliyal, 2017). Organizational citizenship behavior also increases organizational performance (Park, 2018). Civic virtue behavior depends on transformational leadership styles and emotional exhaustion (Khan et al., 2020).

Nurses with high affective commitment will have low levels of burnout and perform well (Sharma & Dhar, 2016). Nurses committed to their work and organization show less intention to leave and keep the team committed to achieving organizational goals (Callado et al., 2023). The more the nurse is effectively committed, the higher the organizational citizenship behavior will be (Gusrita, 2020).

Low work engagement is accompanied by low welfare and performance (Knight et al., 2017). Work engagement can reduce the intention to leave or change jobs (Muchtadin, 2022). High Work Engagement is accompanied by high organizational citizenship behavior (Farid et al., 2019). A strong relationship was found between work engagement and performance (Cesário & Chambel, 2017). Work engagement can increase organizational commitment (W. Kim et al., 2017). Work engagement is caused by personal and work resource development, leadership training, and health promotion (Knight et al., 2017). Job characteristics and organizational support are significant predictors of work engagement. Work engagement predicts organizational commitment, citizenship behavior, job satisfaction, and intention to leave work and mediates the relationship between antecedents and their consequences (Saks, 2019).

This study aims to determine the importance of intrinsic motivation to altruism, civic virtue, affective commitment, and work engagement of Bakti Timah Medika nurses. In the next stage, literature reviews and hypotheses that support this research will be discussed.

2. Literature Review and Hypothesis

Intrinsic Motivation

Self-determination theory (SDT) is a macro theory of human motivation developed from intrinsic and extrinsic motivation and expanded to include research on work organization and life domains other than work (Deci et al., 2017). Intrinsic motivation is an individual's spontaneous tendency to be curious and interested, seek challenges, and develop skills and knowledge, even without reward (Di Domenico & Ryan, 2017). Intrinsic motivation still plays an important role in performance even though incentives have been given (Cerasoli et al., 2014). Self-determination theory can guide the creation of policies, practices, and the environment that lead to high-quality performance (Deci et al., 2017).

Intrinsic motivation is everywhere but is exemplified in games of enthusiastic children to engage in activities without any external reward or encouragement. Intrinsic motivation is also seen in adult

activities even in the workplace (Deci et al., 2017). Intrinsic motivation depends on supporting basic psychological needs such as competence (feeling effective) and autonomy (feeling will) (Di Domenico & Ryan, 2017).

Altruism

Altruism is helping others face-to-face (e.g., helping absent workers, volunteering for unnecessary things, helping new employees when not needed, and helping other workers with high workloads) (Grego-Planer, 2019). Altruism becomes part of organizational citizenship behavior (Solihin & Manurung, 2020). Altruism is behavior intended to increase the welfare of others (Pfattheicher et al., 2022).

Civic Virtue

Civic virtue is the behavior of members of the organization at the individual level, characterized by responsible and constructive involvement of employees in organizational governance issues (Khan et al., 2020). Civic virtue is part of organizational citizenship behavior (Solihin & Manurung, 2020).

Affective Commitment

Affective commitment is an emotional attachment to an organization manifested through involvement (Mercurio, 2015). Affective commitment is an important dimension of organizational commitment, because workers with high affective commitment will exceed contractual expectations and keep the organization running smoothly. (Benkarim & Imbeau, 2021). Organizational commitment consists of affective, normative, and continuance commitment (W. Kim et al., 2017).

Work Engagement

Work engagement is a state of positive motivation through vigor, dedication, and absorption (Bakker et al., 2014). The job demand-resources theory is often used to explain work engagement. This theory proposes that a combination of job characteristics and personal resources predicts job performance through employee work engagement (Bakker & Albrecht, 2018). The characteristics of work engagement include positive emotional states that produce feelings of energy and lead to positive work-oriented behavior (Green et al., 2017).

The Effect of Intrinsic Motivation on Altruism

Workers with high intrinsic motivation tend to display altruistic behavior (Lazauskaite-Zabielske et al., 2015). Intrinsic motivation positively impacts organizational citizenship behavior (altruism, conscientiousness, civic virtue, courtesy, sportsmanship) (Solihin & Manurung, 2020). The higher the intrinsic motivation, the higher the altruism (Güntert, 2015).

The Effect of Intrinsic Motivation on Civic Virtue

Intrinsic motivation positively impacts organizational citizenship behavior (altruism, conscientiousness, civic virtue, courtesy, sportsmanship) (Solihin & Manurung, 2020). Workers with high intrinsic motivation tend to display high civic virtue behavior (Lazauskaite-Zabielske et al., 2015). The higher the intrinsic motivation, the higher the civic virtue (Güntert, 2015).

Effect of Intrinsic Motivation on Affective Commitment

Employees with high intrinsic motivation will be more effectively committed to their organization (Emiyanti et al., 2020). Intrinsic motivation bridges the influence of Islamic work ethics on organizational commitment (Gheitani et al., 2019). A positive relationship between intrinsic motivation and affective commitment was also found (Buch, 2015).

The Effect of Intrinsic Motivation on Work Engagement

Intrinsic motivation was found to play an important role in increasing work engagement (Putra et al., 2015). Work engagement can be increased through intrinsic motivation, spirituality at work, and rewards (Hua et al., 2020). For workers with high intrinsic motivation, the impact given by authentic leadership will be even greater on work engagement (Shu, 2015). Intrinsic motivation positively impacts employee work engagement (Muchtadin, 2023).

3. Data and Method

The research design is quantitative causality, carried out over time. Respondents were 134 Bakti Timah Medika nurses who were taken by accidental sampling. Data analysis used the PLS-SEM method with the help of Smartpls. Measurements of intrinsic motivation, work engagement, affective commitment, altruism, and civic virtue were adapted from previous research (Gagné et al., 2015; H. Kim, 2014; Kristiana et al., 2019).

4. Results

Description of Respondents

The nurses consisted of 98 women and 36 men. As many as 116 nurses were married, and 18 were unmarried. A total of 91 nurses graduated with a diploma, 42 graduated with a bachelor's degree, and 1 graduated with a master's degree. Fourteen nurses aged 18-27 years, 73 aged 28-37 years, 43 aged 38-47 years, 4 aged 48 years and over. A total of 14 nurses worked less than 5 years, 31 nurses worked more than 5 years but less than 10 years, 48 nurses worked more than 10 years but less than 15 years, 26 nurses worked more than 15 years but less than 20 years, 15 nurses worked more than 20 years.

Validity Test

Table 1. AVE Value

Variable	AVE
Altruism	0.552
Civic Virtue	0.542
Affective Commitment	0.622
Intrinsic Motivation	0.743
Work Engagement	0.597

Table 1 contains the AVE values of all variables above 0.5. This result means that all variables are declared valid. The AVE value is obtained after deleting civic virtue items 1 and 4, affective commitment number 2, and work engagement numbers 8 and 9.

Table 2. Outer Loadings

Altruism	Civic Virtue	Affective Commitment	Work Engagement	Intrinsic Motivation
AL2 (0.625)	CV1 (0.715)	KA1 (0.665)	WE1 (0.756)	IM1 (0.870)
AL3 (0.807)	CV2 (0.846)	KA3 (0.813)	WE2 (0.816)	IM2 (0.872)
AL5 (0.782)	CV3 (0.771)	KA4 (0.815)	WE3 (0.729)	IM3 (0.844)
	CV4 (0.588)	KA5 (0.825)	WE4 (0.858)	
		KA6 (0.816)	WE5 (0.820)	
			WE6 (0.707)	
			WE7 (0.709)	

Table 2 contains the outer loading scores for each item from all variables. An outer loading score of less than 0.7 is still used as long as the measurement tool is valid. Altruism items are in the range of 0.625 to 0.807. Civic virtue items are in the range of 0.588 to 0.846. Affective commitment items are in the range of 0.665 to 0.825. Work engagement items are in the range of 0.707 to 0.858. Intrinsic motivation items are in the range of 0.844 to 0.872.

Reliability Test

Table 3. Alfa Cronbach and Composite Reliability

	Alfa Cronbach	Composite Reliability
Altruism	0.609	0.785
Civic virtue	0.738	0.823
Affective Commitment	0.846	0.891
Intrinsic Motivation	0.827	0.897
Work Engagement	0.886	0.912

Table 3 shows the Cronbach's alpha score and composite reliability. All variables have a composite reliability score above 0.7, so the measuring instrument is declared reliable.

R Square Test

Table 4. R Square

Variable	R Square
Altruism	0.143
Civic Virtue	0.143
Affective Commitment	0.248
Work Engagement	0.594

Table 4 contains the R Square value where intrinsic motivation contributes to altruism by 14.3% while factors outside the research cause 85.7%. Intrinsic motivation contributes to civic virtue by 14.3%, while other factors cause 85.7%. Intrinsic motivation contributes to affective commitment by 24.8%, while factors outside the research cause 75.2%. Intrinsic motivation contributes to work engagement by 59.4%, while 40.6% is due to other factors. Intrinsic motivation has the biggest contribution to work engagement.

F Square Test

Table 5. F Square

	Intrinsic Motivation
Altruism	0.167
Civic Virtue	0.167
Affective Commitment	0.340
Work Engagement	1.484

Table 5 contains F values where the values of altruism, civic virtue, and affective commitment are in the range of 0.15 and lower than 0.35, which means that intrinsic motivation has a moderate effect on these three variables. The impact of intrinsic motivation on work engagement has a value of 0.35 and above (1.484), which means it has a large effect. Based on the F square test, work engagement has the greatest influence on intrinsic motivation.

Path Coefficient

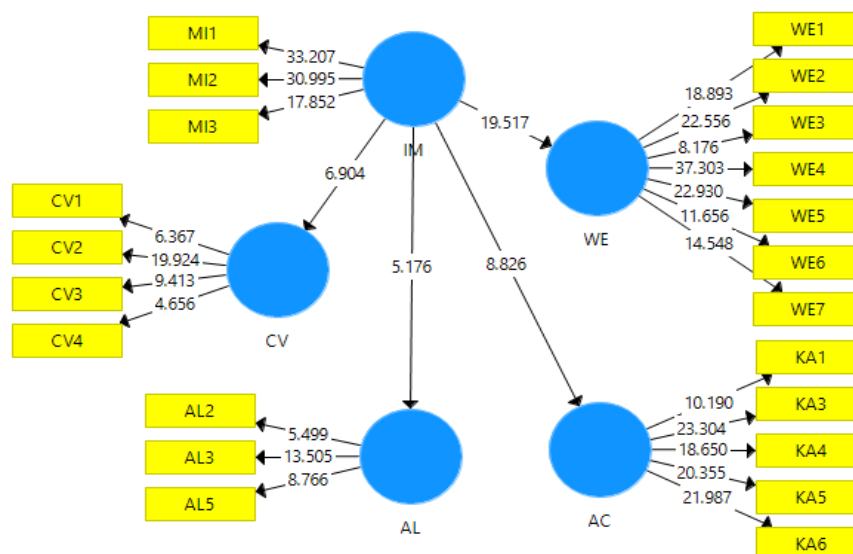

Figure 1. Path Coefficient

Figure 1 shows the direction of the influence of intrinsic motivation on altruism at 5.176 (> 1.96), the effect of intrinsic motivation on civic virtue at 6.904 (> 1.96), the effect of intrinsic motivation on affective commitment at 8.826 (> 1.96), the influence of intrinsic motivation for work engagement is 19.517 (> 1.96). These results indicate that intrinsic motivation increases altruism, civic virtue, affective commitment, and work engagement from nurses.

Hypothesis Testing

Table 6. Hypothesis Testing

	Original Sample	T Statistics	P Values
Intrinsic Motivation ► Altruism	0.378	5.167	0.000
Intrinsic motivation ► Civic Virtue	0.379	6.904	0.000
Intrinsic motivation ► Affective Commitment	0.504	8.826	0.000
Intrinsic Motivation ► Work Engagement	0.773	19.517	0.000

Table 6 shows the results of hypothesis testing where intrinsic motivation has the greatest influence on work engagement (correlation level = 0.773 and T statistics = 19.517) compared to altruism, civic virtue, and affective commitment. All P values were 0.000 (< 0.05), indicating that the research hypothesis was accepted. The results of hypothesis testing found that intrinsic motivation had a significant positive impact on altruism, civic virtue, affective commitment, and work engagement seen from P Values (< 0.05) and T statistics (> 1.96).

5. Discussion

The majority of respondents in this study were women, married, diploma graduates, aged 28 to 37 years, and had worked for more than 10 years but less than 15 years. The total respondents were 134 Bakti Timah Medika nurses.

The study's results found a significant positive effect of intrinsic motivation on altruism. This result is supported by previous findings (Güntert, 2015; Lazauskaite-Zabielske et al., 2015; Solihin & Manurung, 2020). This finding means that when nurses are motivated by enjoying their work, they are more inclined to help their co-workers voluntarily.

The significant positive effect of intrinsic motivation on civic virtue is found in this study. These results are supported by previous studies (Güntert, 2015; Lazauskaite-Zabielske et al., 2015; Solihin & Manurung, 2020). When nurses are motivated because their work is fun, nurses will be more involved and responsible for organizational governance.

This study found a significant positive effect of intrinsic motivation on affective commitment and is supported by several previous findings (Buch, 2015; Emiyanti et al., 2020; Gheitani et al., 2019). Nurses who are motivated by enjoying their work will be more emotionally committed and more involved with their organization.

The study's results found a significant positive impact of intrinsic motivation on work engagement and are supported by previous findings (Hua et al., 2020; Muchtadin, 2023; Putra et al., 2015; Shu, 2015). Nurses motivated by a job that feels good will become passionate, dedicated, and absorbed in their work.

Intrinsic motivation has the greatest impact on work engagement, followed by affective commitment, civic virtue, and altruism (Table 6). This finding indicates that civic virtue and altruism must first go through work engagement before intrinsic influences affective commitment. Work engagement is positively related to organizational citizenship behavior and organizational commitment (Abu-Shamaa et al., 2015; Farid et al., 2019). Work engagement is thought to bridge intrinsic motivation's influence on the components of organizational citizenship behavior and organizational commitment.

Intrinsic motivation from nurses can be increased through freedom in work, meaningfulness in doing work, support from colleagues, and empowering competencies possessed (Swiatczak, 2021). Spirituality in the workplace can also make workers more intrinsically motivated (Afsar et al., 2016). When individuals express interest, curiosity, enjoyment, and other positive feelings, the individual is intrinsically motivated (Fishbach & Woolley, 2022).

This study only uses the work itself dimension adapted from (Gagné et al., 2015). Other researchers argue that intrinsic motivation has dimensions such as impact, competence, meaning, autonomy, social relatedness, and work (Swiatczak, 2021).

6. Conclusion

The conclusion that can be drawn is that a nurse's intrinsic motivation has a significant positive impact on altruism, civic virtue, affective commitment, and work engagement. The impact of intrinsic motivation on work engagement is the greatest. Future research can use work engagement as a mediating variable on the influence of intrinsic motivation on altruism, civic virtue, and affective commitment. Future researchers can add to the population in other hospitals. Hospital management should be expected to increase nurses' intrinsic motivation by creating a comfortable work environment, having autonomy at work, creating mutually supportive co-workers, and providing fair training to all nurses.

References

- Abu-Shamaa, R., Al-Rabayah, W. A., & Khasawneh, R. T. (2015). The effect of job satisfaction and work engagement on organizational commitment. *IUP Journal of Organizational Behavior*, 14(4).
- Afsar, B., Badir, Y., & Kiani, U. S. (2016). Linking spiritual leadership and employee pro-environmental behavior: The influence of workplace spirituality, intrinsic motivation, and environmental passion. *Journal of Environmental Psychology*, 45, 79–88. <https://doi.org/10.1016/j.jenvp.2015.11.011>
- Bakker, A. B., & Albrecht, S. (2018). Work engagement: current trends. *Career Development International*, 23(1), 4–11. <https://doi.org/10.1108/CDI-11-2017-0207>
- Bakker, A. B., Demerouti, E., & Sanz-Vergel, A. I. (2014). Burnout and Work Engagement: The JD–R Approach. *Annual Review of Organizational Psychology and Organizational Behavior*, 1(1), 389–411. <https://doi.org/10.1146/annurev-orgpsych-031413-091235>
- Benkarim, A., & Imbeau, D. (2021). Organizational Commitment and Lean Sustainability: Literature Review and Directions for Future Research. In *Sustainability* (Vol. 13, Issue 6). <https://doi.org/10.3390/su13063357>
- Buch, R. (2015). Leader–member exchange as a moderator of the relationship between employee–organization exchange and affective commitment. *The International Journal of Human Resource Management*, 26(1), 59–79. <https://doi.org/10.1080/09585192.2014.934897>
- Callado, A., Teixeira, G., & Lucas, P. (2023). Turnover Intention and Organizational Commitment of Primary Healthcare Nurses. In *Healthcare* (Vol. 11, Issue 4). <https://doi.org/10.3390/healthcare11040521>
- Carr, P. B., & Walton, G. M. (2014). Cues of working together fuel intrinsic motivation. *Journal of Experimental Social Psychology*, 53, 169–184. <https://doi.org/10.1016/j.jesp.2014.03.015>
- Cerasoli, C. P., Nicklin, J. M., & Ford, M. T. (2014). Intrinsic motivation and extrinsic incentives jointly predict performance: A 40-year meta-analysis. In *Psychological Bulletin* (Vol. 140, Issue 4, pp. 980–1008). American Psychological Association. <https://doi.org/10.1037/a0035661>
- Cesário, F., & Chambel, M. J. (2017). Linking Organizational Commitment and Work Engagement to Employee Performance. *Knowledge and Process Management*, 24(2), 152–158. <https://doi.org/10.1002/kpm.1542>
- Deci, E. L., Olafsen, A. H., & Ryan, R. M. (2017). Self-Determination Theory in Work Organizations: The State of a Science. *Annual Review of Organizational Psychology and Organizational Behavior*, 4(1), 19–43. <https://doi.org/10.1146/annurev-orgpsych-032516-113108>

- Di Domenico, S. I., & Ryan, R. M. (2017). The Emerging Neuroscience of Intrinsic Motivation: A New Frontier in Self-Determination Research. In *Frontiers in Human Neuroscience* (Vol. 11). <https://www.frontiersin.org/articles/10.3389/fnhum.2017.00145>
- Emiyanti, L., Rochaida, E., & Tricahyadinata, I. (2020). Pengaruh Karakteristik Individu Dan Motivasi Intrinsik Terhadap Komitmen Afektif Dan Kinerja Pegawai. *The Manager Review*, 15–24.
- Farid, T., Iqbal, S., Ma, J., Castro-González, S., Khattak, A., & Khan, M. K. (2019). Employees' Perceptions of CSR, Work Engagement, and Organizational Citizenship Behavior: The Mediating Effects of Organizational Justice. In *International Journal of Environmental Research and Public Health* (Vol. 16, Issue 10). <https://doi.org/10.3390/ijerph16101731>
- Fishbach, A., & Woolley, K. (2022). The Structure of Intrinsic Motivation. *Annual Review of Organizational Psychology and Organizational Behavior*, 9(1), 339–363. <https://doi.org/10.1146/annurev-orgpsych-012420-091122>
- Gagné, M., Forest, J., Vansteenkiste, M., Crevier-Braud, L., Van den Broeck, A., Aspel, A. K., Bellerose, J., Benabou, C., Chemolli, E., & Güntert, S. T. (2015). The Multidimensional Work Motivation Scale: Validation evidence in seven languages and nine countries. *European Journal of Work and Organizational Psychology*, 24(2), 178–196.
- Gheitani, A., Imani, S., Seyyedamiri, N., & Foroudi, P. (2019). Mediating effect of intrinsic motivation on the relationship between Islamic work ethic, job satisfaction, and organizational commitment in banking sector. *International Journal of Islamic and Middle Eastern Finance and Management*, 12(1), 76–95. <https://doi.org/10.1108/IMEFM-01-2018-0029>
- Green, P. I., Finkel, E. J., Fitzsimons, G. M., & Gino, F. (2017). The energizing nature of work engagement: Toward a new need-based theory of work motivation. *Research in Organizational Behavior*, 37, 1–18. <https://doi.org/10.1016/j.riob.2017.10.007>
- Grego-Planer, D. (2019). The Relationship between Organizational Commitment and Organizational Citizenship Behaviors in the Public and Private Sectors. In *Sustainability* (Vol. 11, Issue 22). <https://doi.org/10.3390/su11226395>
- Güntert, S. T. (2015). The impact of work design, autonomy support, and strategy on employee outcomes: A differentiated perspective on self-determination at work. *Motivation and Emotion*, 39(1), 74–87. <https://doi.org/10.1007/s11031-014-9412-7>
- Gusrita, S. (2020). Effect of Affective Commitment on Organizational Citizenship Behavior and Emotional Performance with Emotional Intelligence as a Moderation Variable on Nurse Handling of COVID-19 RSUP Dr. M. Djamil Padang. *Proceedings of the 5th Padang International Conference on Economics Education, Economics, Business and Management, Accounting and Entrepreneurship*, 972–983.
- Hua, Y., Cheng, X., Hou, T., & Luo, R. (2020). Monetary rewards, intrinsic motivators, and work engagement in the IT-enabled sharing economy: A mixed-methods investigation of Internet taxi drivers. *Decision Sciences*, 51(3), 755–785.
- Jennings, N., Clifford, S., Fox, A. R., O'Connell, J., & Gardner, G. (2015). The impact of nurse practitioner services on cost, quality of care, satisfaction and waiting times in the emergency department: A systematic review. *International Journal of Nursing Studies*, 52(1), 421–435. <https://doi.org/10.1016/j.ijnurstu.2014.07.006>
- Khan, N. A., Khan, A. N., Soomro, M. A., & Khan, S. K. (2020). Transformational leadership and civic virtue behavior: Valuing act of thriving and emotional exhaustion in the hotel industry. *Asia Pacific Management Review*, 25(4), 216–225. <https://doi.org/10.1016/j.apmr.2020.05.001>
- Kim, H. (2014). Transformational Leadership, Organizational Clan Culture, Organizational Affective Commitment, and Organizational Citizenship Behavior: A Case of South Korea's Public Sector. *Public Organization Review*, 14(3), 397–417. <https://doi.org/10.1007/s11115-013-0225-z>
- Kim, W., Kim, J., Woo, H., Park, J., Jo, J., Park, S.-H., & Lim, S. Y. (2017). The Relationship Between Work Engagement and Organizational Commitment: Proposing Research Agendas Through a Review of Empirical Literature. *Human Resource Development Review*, 16(4), 350–376. <https://doi.org/10.1177/1534484317725967>
- Knight, C., Patterson, M., & Dawson, J. (2017). Building work engagement: A systematic review and meta-analysis investigating the effectiveness of work engagement interventions. *Journal of Organizational Behavior*, 38(6), 792–812. <https://doi.org/10.1002/job.2167>

- Kristiana, I. F., Fajrianti, F., & Purwono, U. (2019). Analisis Rasch Dalam Utrecht Work Engagement Scale-9 (Uwes-9) Versi Bahasa Indonesia. *Jurnal Psikologi*, 17(2), 204. <https://doi.org/10.14710/jp.17.2.204-217>
- Kumari, P., & Thapliyal, S. (2017). Studying the Impact of Organizational Citizenship Behavior on Organizational Effectiveness. *International Academic Journal of Organizational Behavior and Human Resource Management*, 4(1), 9–21.
- Lazauskaite-Zabielske, J., Urbanaviciute, I., & Bagdziuniene, D. (2015). The role of prosocial and intrinsic motivation in employees' citizenship behaviour. *Baltic Journal of Management*, 10(3), 345–365. <https://doi.org/10.1108/BJM-05-2014-0085>
- Mercurio, Z. A. (2015). Affective Commitment as a Core Essence of Organizational Commitment: An Integrative Literature Review. *Human Resource Development Review*, 14(4), 389–414. <https://doi.org/10.1177/1534484315603612>
- Muchtadin. (2023). Pengaruh Lingkungan Kerja terhadap Work Engagement Melalui Motivasi Intrinsik Dosen. *Journal of Accounting, Management and Economics Research*, 2(1), 11–22. <https://doi.org/10.33476/jamer.v2i1.48>
- Muchtadin, M. (2022). Hubungan antara Work Engagement dengan Turnover Intention pada Pekerja Generasi Milenial di Jabodetabek. *Jurnal Psikologi Teori Dan Terapan*, 13(3), 377–391. <https://doi.org/10.26740/jptt.v13n3.p377-391>
- Park, R. (2018). The roles of OCB and automation in the relationship between job autonomy and organizational performance: a moderated mediation model. *The International Journal of Human Resource Management*, 29(6), 1139–1156. <https://doi.org/10.1080/09585192.2016.1180315>
- Pfattheicher, S., Nielsen, Y. A., & Thielmann, I. (2022). Prosocial behavior and altruism: A review of concepts and definitions. *Current Opinion in Psychology*, 44, 124–129. <https://doi.org/10.1016/j.copsyc.2021.08.021>
- Putra, E. D., Cho, S., & Liu, J. (2015). Extrinsic and intrinsic motivation on work engagement in the hospitality industry: Test of motivation crowding theory. *Tourism and Hospitality Research*, 17(2), 228–241. <https://doi.org/10.1177/1467358415613393>
- Saks, A. M. (2019). Antecedents and consequences of employee engagement revisited. *Journal of Organizational Effectiveness: People and Performance*, 6(1), 19–38. <https://doi.org/10.1108/JOEPP-06-2018-0034>
- Sharma, J., & Dhar, R. L. (2016). Factors influencing job performance of nursing staff. *Personnel Review*, 45(1), 161–182. <https://doi.org/10.1108/PR-01-2014-0007>
- Shu, C.-Y. (2015). The Impact of Intrinsic Motivation on The Effectiveness of Leadership Style towards on Work Engagement. *Contemporary Management Research*, 11(4), 327–350. <https://doi.org/10.7903/cmr.14043>
- Solihin, I., & Manurung, A. D. R. (2020). Influence of Situational Leadership, Extrinsic Motivation, and Intrinsic Motivation on Organizational Citizenship Behavior (OCB) in State Civil Apparatus (ASN) In Local Government Pandeglang District of Banten Province. *International Journal of Innovative Science and Research Technology*, 5(2), 246–257.
- Swiatczak, M. D. (2021). Towards a neo-configurational theory of intrinsic motivation. *Motivation and Emotion*, 45(6), 769–789. <https://doi.org/10.1007/s11031-021-09906-1>
- Toode, K., Routasalo, P., Helminen, M., & Suominen, T. (2015). Hospital nurses' work motivation. *Scandinavian Journal of Caring Sciences*, 29(2), 248–257. <https://doi.org/10.1111/scs.12155>
- Wang, E., Hu, H., Mao, S., & Liu, H. (2019). Intrinsic motivation and turnover intention among geriatric nurses employed in nursing homes: the roles of job burnout and pay satisfaction. *Contemporary Nurse*, 55(2–3), 195–210. <https://doi.org/10.1080/10376178.2019.1641120>